

Det. Top Of Pole
SCALE 1 : 25

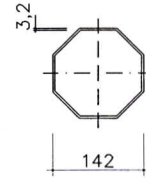

Det. Bottom Of Pole
SCALE 1 : 25

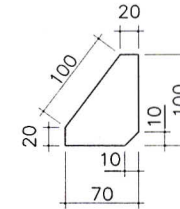

Det. Rip Plate
SCALE 1 : 25

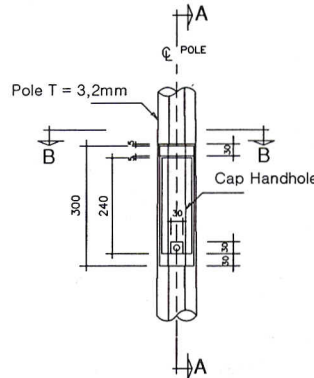

Det 2. Handhole
SCALE 1 : 25

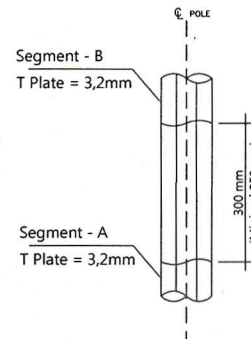

Det 3. Slip Joint
SCALE 1 : 25

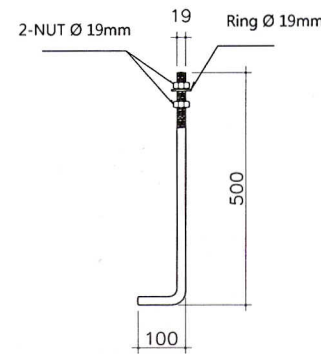

Det. Anchor Bolt
SCALE 1 : 25

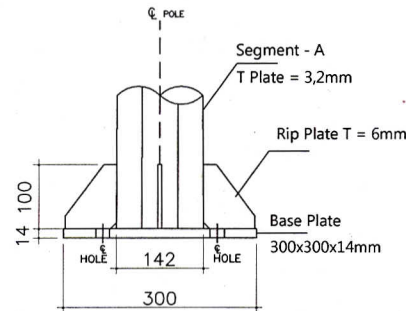

DET. 1 Base Plate
SCALE 1 : 25

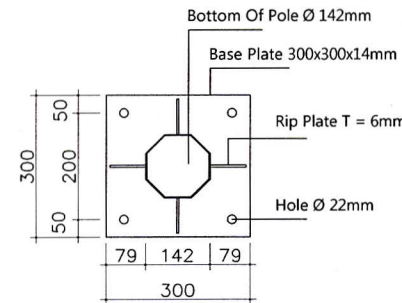

DET. 1 Base Plate
SCALE 1 : 25

TIANG PJU H-09M SINGLE PARABOLE
SCALE 1 : 25

OCTAGONAL

KETERANGAN

STANDART MUTU :

- ISO 9001 : 2008
- Plate Baja : ST 41 / SS 400
- Welding : Las Listrik
- Finishing Hot Dip Galvanize
- Segment System Slip Joint
- Segment A = 6000mm
- Segment B = 3300mm
- Bottom Of Pole Ø 142mm
- Base Plate 300x300x14mm

PRODUCTION :



PT. HELORI GRAHASARANA

JOB TITLE :

TECHNICAL SPECIFICATION

CLIENT :

PRODDJECT :

DRAWING TITLE :

TIANG PJU OCTAGONAL
H-09M SINGLE PARABOLE

DATE	CLIENT APPROVAL	APPROVAL
	PT. Helori Grahasarana	Risawan. W
CAD	DESIGN	CHECK
Auto CAD 2009	Dwi. Y	Efi
DRAWING NO : RL-SP-H09	SHEET NO : SHEET 1 Of 1	